

HYGHSPIN

Twin Screw Pumps – hygienic,
high-performance, gentle treatment.



- Pumping of aqueous and highly viscous media
- High suction capacity
- Handling of product and CIP media with only one pump
- Gentle treatment
- Abrasion-free



Development, Manufacture, Assembly.

The series HYGHSPIN was developed for highest demands with regard to precision and hygiene. HYGHSPIN complies with the quality requirements for the food and beverage industry and is also optimally suitable for many appliances in the chemical and pharmaceutical industry. Our own production site offers flexibility and is certified as per ISO 9001:2008.



Characteristics.

- Pumping of aqueous and highly viscous media
- High suction performance
- Product and CIP with only one pump
- Pumping of fibrous media and products containing pieces
- Gentle treatment
- Abrasion-free – no contact between the feeding elements
- Supply rates up to 200m³/h
- EHEDG certified
- Simple assembly and disassembly
- Technical advisory service and optimization for all fields of application
- GOST R-certification

Outputs.

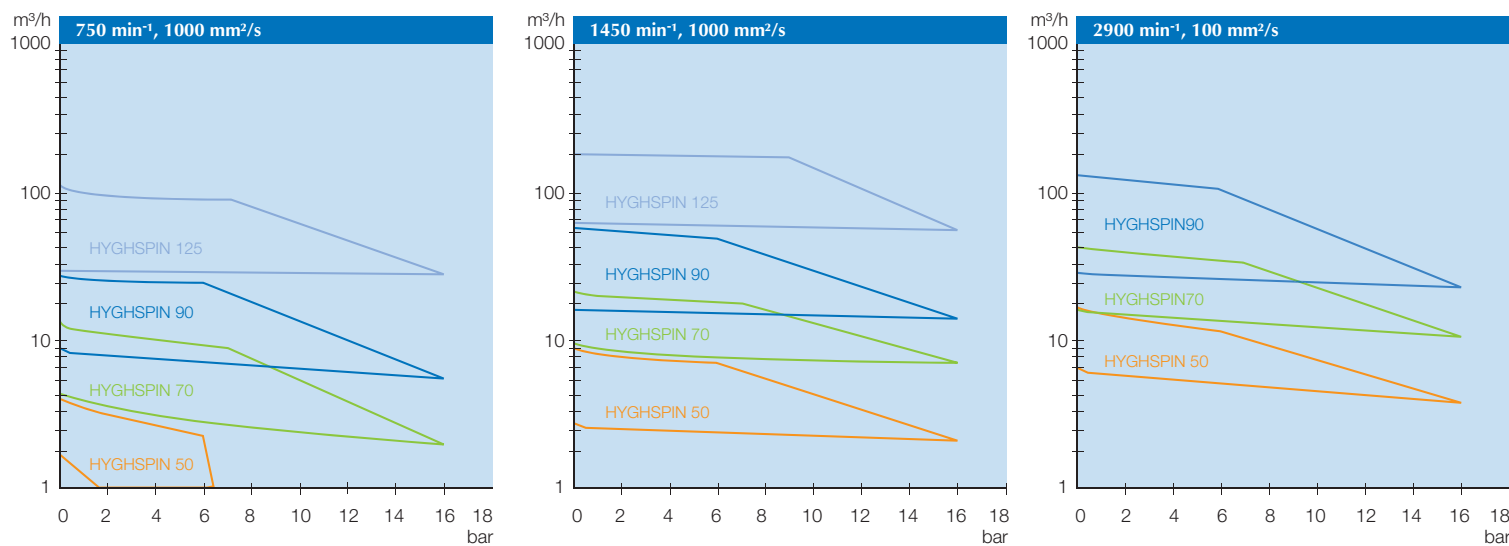

- Balanced feeding elements with different pitches
- Speed control 5 – 120 Hz – product feed and cleaning with only one pump
- Excellent suction performance and low NPSHr-values
- Axial gentle feeding of product
- Pumping of media containing pieces
- Feeding of gas-loaded media

- Hygienic sealing by form rings – no dead spaces
- FDA approved elastomers with different qualities

Quick assembly/disassembly of the components allowing manual cleaning

- Product infeed (reversible pumping is possible)
- Various standards and nominal widths available
- Horizontal discharge for perfect emptying

Electro-polished surfaces for optimum cleaning (Ra < 0,8)

Exact positioning of the components due to precise manufacture

Pump housing with wear-resistant JUNG-Chromcarbide coating

Same space requirements for double-acting and single-acting mechanical seals

Stainless steel bearing support with high-capacity features

Drive shaft with adjusting key connection

Precision gear wheels guarantee non-contact operation of the feeding elements

Gear housing made of aluminium with wear- and acid-resistant Teflon coating

Hardened shafts in the area of shaft sealing rings – no wear and no oil loss

Connections for mechanical seal rinsing



One pump for numerous industries.

- Beverage industry
- Breweries
- Delicatessen industry
- Bakery products
- Confectionery
- Dairies and the milk industry
- Butchers
- Cosmetics and pharmacy
- Industry

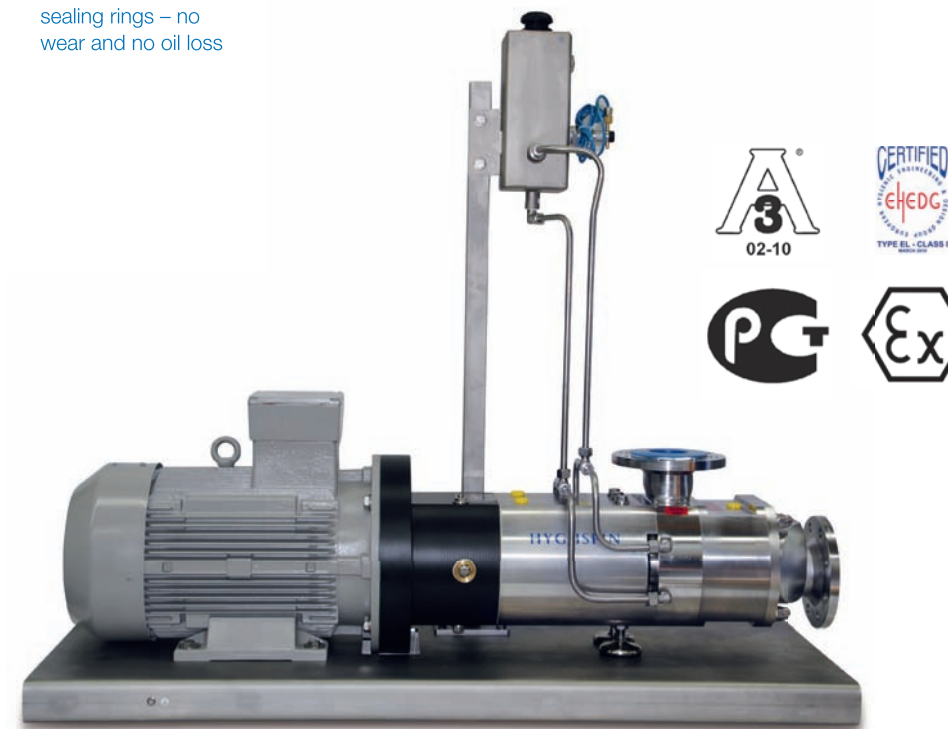

Technical Data.

Overview of the individual pump sizes.

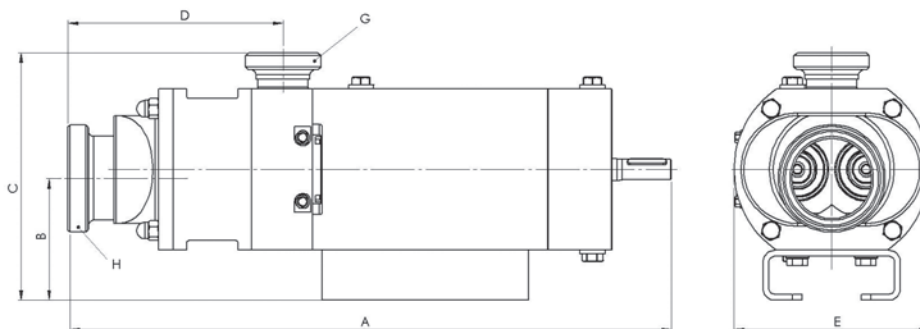

Type	Capacity	Max. diam. of solid matter Ø	Dimensions (mm)					Connection flange	cover	weight
			A	B	C	D	E			
HYGHSPIN 70	100l/h – 30m³/h	20 mm	615	124	252	219	199	2" or DN50	2" or DN50 3" or DN80	65 kg
HYGHSPIN 90	1m³/h – 80m³/h	28 mm	723	146	342	275	259	2,5" or DN65	3" or DN80 4" or DN100	128 kg
HYGHSPIN 125	10m³/h – 200m³/h	45 mm	1004	212	491	280	249	3" or DN80	4" or DN100 6" or DN150	365 kg

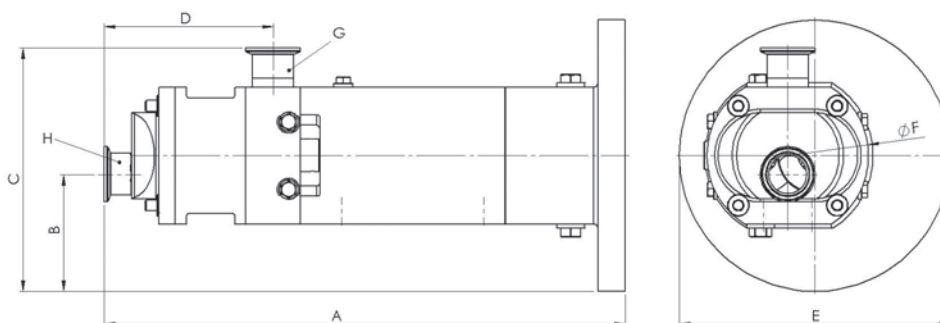

Type	Capacity	Max. diam. of solid matter Ø	Dimensions (mm)						Connection flange	cover	weight
			A	B	C	D	E	F			
HYGHSPIN 50B	30l/h – 15m³/h	15 mm	495	108	224	156	250	149	1½" or DN40	1½" or DN40 2" or DN50	37 kg
HYGHSPIN 70B	100l/h – 30m³/h	20 mm	650	200	295	209	350	199	2" or DN50	2" or DN50 3" or DN80	68 kg
HYGHSPIN 90B	1m³/h – 80m³/h	28 mm	785	148	334	275	350	259	2,5" or DN65	3" or DN80 4" or DN100	150 kg

Overview.

Performance features	
Capacity	30l/h – 200m³/h
Differential pressure	16bar, optional 25bar
Suction capacity	NPSHr up to 0,5 m
Viscosity	0,5 – 1.000.000 cSt
Product temperature	-10 – 130°C, with oil cooler 160°C
Cleaning temperature	140°C
Sterilization temperature	up to 145°C
Product-contact parts made of	1.4404 with 3.1 certificate (other materials upon request)
Elastomers	HNBR and FDA approved (other elastomers upon request)



www.jung-process-systems.de